**COMPUTER TECHNOLOGIES
IN PHYSICS**

Scientific Computing Infrastructure and Services in Moldova¹

P. P. Bogatencov^{b, *}, G. V. Secieru^{a, **}, N. V. Degteariov^a, and N. P. Iliuha^b

^a*The Institute of Mathematics and Computer Science of ASM, Chisinau, Moldova*

^b*RENAM Association, Chisinau, Moldova*

**e-mail: bogatencov@renam.md*

***e-mail: secieru@cc.acad.md*

Received January 5, 2016

Abstract—In recent years distributed information processing and high-performance computing technologies (HPC, distributed Cloud and Grid computing infrastructures) for solving complex tasks with high demands of computing resources are actively developing. In Moldova the works on creation of high-performance and distributed computing infrastructures were started relatively recently due to participation in implementation of a number of international projects. Research teams from Moldova participated in a series of regional and pan-European projects that allowed them to begin forming the national heterogeneous computing infrastructure, get access to regional and European computing resources, and expand the range and areas of solving tasks.

DOI: 10.1134/S1547477116050125

INTRODUCTION

The development of national scientific computing infrastructure in Moldova since 2007 is coordinating by MD-GRID NGI (National Grid Initiative). Now NGI unites nine principal research and educational entities that involved in providing computational resources, support of development and use of national HPC and distributed computing infrastructure and applications.

National Scientific Computing infrastructure is based on using specialized parallel architectures for running complex applications and integrates the following components:

- Grid distributed computing infrastructures;
- HPC – Clusters’ systems;
- Scientific Clouds;
- Libraries and software packages for parallel algorithms design and programming;
- Instruments for complex applications development, debugging and porting.

MD-GRID DEVELOPMENT

The scientific computing resources in Moldova had begun developing by deployment in 2006 of the first Grid cluster that was integrated in the regional South-East Europe Grid infrastructure. These specific and new for Moldova activities were supported by a serious of the regional SEE-GRID projects [1].

These projects allowed establishing strong human network in the area of scientific computing and set up a powerful regional Grid infrastructure. One of main objectives of the SEE-GRID projects was to involve new research and academic institutes and scientific communities in the region, with emphasis on the deployment and support of a wide range of Grid applications.

The initially accumulated experience was successful from the point of view of forming professional team of specialists in the area of distributed computing and examination of potential users’ communities needs in computational resources that pave the way for creation of the prepared national users’ community. The main activity directions of the created in Moldova NGI can be summarized as following:

- MD-Grid NGI participates in strategic European Programs for the development of transnational distributed computing technologies and in initiatives for the completion of regional e-Infrastructures. MD-Grid NGI implements the general EU policy on the development of national e-Infrastructures and especially scientific computing infrastructures.

- The integration of distributed computing development actions (infrastructures, middleware and applications) with the broadband network into a standard e-Infrastructures system. The optimization of exploitation of advanced network resources and services, which can serve the new e-Science generation and will attract the greater users’ community of the information society to the mass adoption of advanced services provided by modern computing architectures.

¹ The article is published in the original.

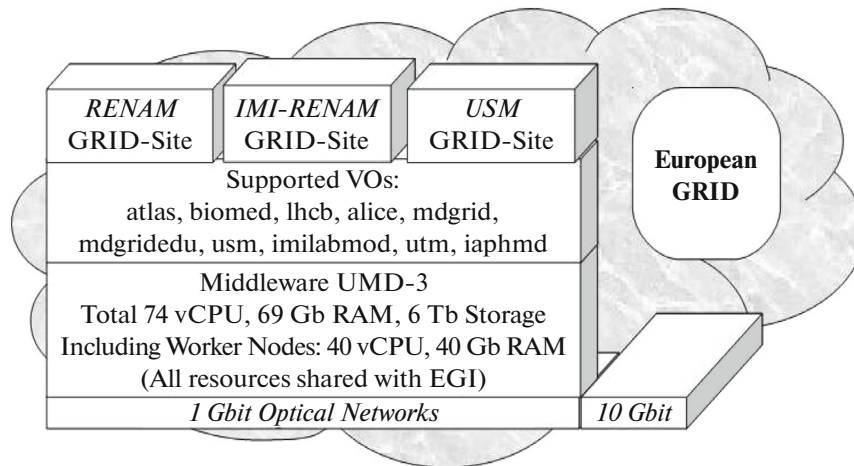

Fig. 1. MD-Grid current infrastructure.

- The permanent development and administration of the computing infrastructure.
- The organization access for national users' communities to the national, regional and European computational resources (HPC, Grid, scientific clouds, etc.).
- The educational and training events organization; the technological and consultancy support of national users' communities.

At present Grid infrastructure in Moldova unites three sites and has well determined perspectives for its further enlargement (Fig. 1). NGI is offering R&E PKI operational support, providing federated identity management, providing other specific informational and computational services. Another principal task that is in focus of NGI is attracting new research teams that have requirements in complex applications development and in access to powerful computing resources [2]. NGI regular organizing national seminars and conferences, on which broadcast the up to date experience in creating and using e-Infrastructures (research networking, HPC, Grid, scientific data repositories, etc.).

The development of national Grid infrastructures in 2010–2014 was coordinating by EGI-InSPIRE pan-European project led by European Grid Initiative (EGI). EGI-InSPIRE activities covered grids of high-performance computing, high-throughput computing (HTC) resources and Distributed Computing Infrastructures (DCIs) such as clouds.

NATIONAL HPC RESOURCES

National HPC resources begun developing in 2007, due to realization of the project supported by CRDF-MRDA Foundation. At this time, the first computing cluster with parallel architecture configured by Hewlett-Packard Company was installed in the State University of Moldova. At the same time, the Institute of

Mathematics and Computer Science of ASM and RENAM Association with support of the European SEE-GRID regional projects and bilateral co-operation project funded by ASM and Russian Foundation for Fundamental Research jointly installed the second multiprocessor cluster. They both are mid-size computational installations and used mainly for applications development, testing and debugging.

Important for Moldova was participation in the regional project HP-SEE (High-Performance Computing Infrastructure for South East Europe's Research Communities) that allowed for local research and educational institutions to get access to regional HPC resources [3]. Regional HPC infrastructure combines powerful HPC clusters and various supercomputers provided by the project participants from five countries involved in the project: Greece, Bulgaria, Romania, Hungary and Serbia.

During HP-SEE project realization in Moldova have been identified and proposed for implementation several technologies and tools for offering access to advanced computing resources and services that developing for researchers from Eastern Europe. Members of the project from Moldova participated in a series of specialized trainings. In the framework of HP-SEE project in 2012 was signed the Cooperation Agreement between RENAM and computer centers in South-Eastern Europe that determines conditions of providing access for research teams from Moldova to the regional high performance computing resources.

The development of scientific clouds is perspective direction of computational technologies development for research and education. The needs of cloud computing technologies deployment in Moldova were analyzed during realization of EC SEERA-EI project ("South-East European Research Area for e-Infrastructures"). The carried out analysis had shown strong interest of the regional and especially Moldo-

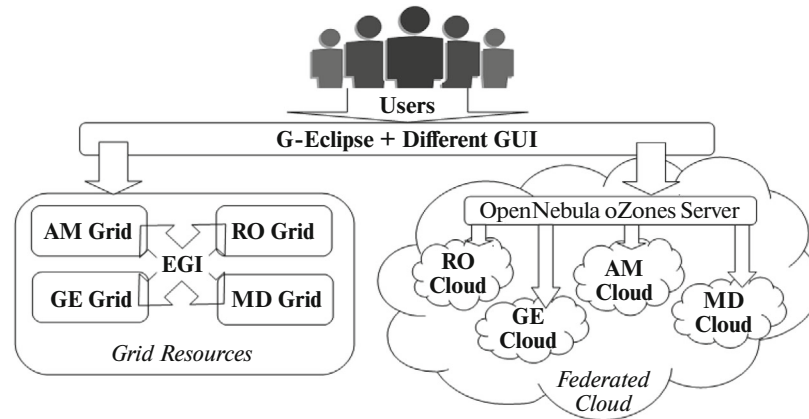

Fig. 2. “BSEC gEclipseGrid” regional platform.

van research communities in scientific clouds deployment.

MD SCIENTIFIC CLOUD

The first practical results on deploying of open source Cloud computing infrastructures for research and educational area were obtained during RENAM Association participation in the regional project “Experimental Deployment of an Integrated Grid and Cloud Enabled Environment in BSEC Countries on the Base of g-Eclipse (BSEC gEclipseGrid)”. The main purpose of the project was to deploy a regional integrated Grid and Cloud enabled environment based on g-Eclipse for the South-East Europe region including Armenia, Georgia, Moldova and Romania [4]. The principal approach proposed for implementation in the BSEC regional project is the ability of realization of computational environment that will combine Grid and Cloud resources to offer the computational power that can adaptively, on demand allocate resources depending on specific workflow requirements (Fig. 2).

In the “BSEC gEclipseGrid” project the distributed Cloud computing platform was deployed using OpenNebula 4.4.1 middleware. The national Cloud resources have been joined together using the OpenNebula Zones (oZones), which allows centralized management of multiple instances of OpenNebula and especially designed to create federated Cloud infrastructure. Disk images with preinstalled applications for solving computational problems in different scientific domains such as environment, meteorology, seismology and astrophysics were integrated in this regional Cloud infrastructure.

Organization of federated access to Cloud computing resources is a very important component of every federated cloud computing infrastructure operation. For the considering cloud infrastructure there were no unified solutions that could provide unified federated

access and be integrated in the identity management federations operated within eduGAIN inter-federation authorization and authentication mechanism (AAI). The first practical results in the area of implementation of unified federated access was obtained due to participation in EGI-Inspire AAI Cloud Pilot project “Federated AAI for NREN services” and during deployment and administration of OpenStack cloud infrastructure, which stands in a basement of GN3plus project service activity SA2 – GEANT Test-bed Service.

The works of the team from Moldova in the above-mentioned initiatives pushed us to deploy additional Cloud computing infrastructure on the base of OpenStack middleware. OpenStack cloud middleware is highly configurable to meet different needs with various computing, networking, and storage options. These middleware components provide flexible and adaptive functionality that can be used for building any types of Clouds: private, public, mixed and those Clouds can be of any complexity and scale.

For OpenStack cloud resources deployment we used Ubuntu Server 14.04 LTS as a base operation system for all nodes and the latest version of OpenStack release “Juno”. Internet connectivity and internal networking for virtual machines provided via the Network Node. The Network Node runs SDN (Software Defined Network) technology software – Open Virtual Switch. It creates virtual network infrastructure for virtual machines and segregates different network slices using GRE (Generic Routing Encapsulation) tunneling protocol and supports many other networking protocols including OpenFlow.

Existing HPC, Grid and cloud resources integrated in the common national optical networking segment that offers the necessary QoS connection of all national computational resources. The optical gateway to GEANT infrastructure integrates national computing installations to the regional and European e-Infrastructures.

Important initiative was launched in May 2010, when the Academy of Sciences of Moldova and RENAM Association had signed a Memorandum of Cooperation with the Joint Institute for Nuclear Research (Dubna, Russia), which related to cooperation in the field of joint development and use of HPC and distributed computing infrastructures. This Memorandum strengthened cooperation between researchers from different countries and creates conditions for solving complex problems without the need for scientists to travel to resource centers for getting access to computational resources.

CONCLUSION

Virtualization and Cloud technologies give resource providers flexible tools for effective resource manipulation in different computing infrastructures. This approach is using for integrated computing infrastructure deployment in Moldova.

Participation in realization of e-Infrastructure development projects allowing national research communities from Moldova to get access to the computing resources of leadership-class capability and remain competitive at the European and international level.

REFERENCES

1. S. M. Andronic, A. T. Altuhov, P. P. Bogatencov, V. V. Pocotilenco, G. V. Secrieru, and V. D. Sidorenco, "SEEGRID project of the development of Grid infrastructure in Eastern Europe countries," in *Proceedings of 1st National Conference on Telecommunications, Electronics and Informatics* (UTM, Chisinau, 2006), pp. 89–91.
2. A. A. Andries, P. P. Bogatencov, G. V. Secrieru, V. D. Sidorenco, A. T. Altuhov, and V. V. Pocotilenco, "MD-GRID NGI developement," in *Proceedings of the International Conference ICT+ on Information and Communication Technologies 2009, Chisinau, May, 18–21, 2009*, pp. 11–14.
3. N. P. Iliuha, A. T. Altuhov, P. P. Bogatencov, G. V. Secrieru, and A. V. Golubev, "SEE-HP project – providing access to the regional high performance computing infrastructure," in *Proceedings of the International Workshop on Intelligent Information Systems IIS, Chisinau, Sept. 13–14, 2011*, pp. 183–186.
4. P. P. Bogatencov, N. V. Degtarirov, N. P. Iliuha, and P. M. Vaseanovici, "Implementation of scientific cloud testing infrastructure in Moldova," in *Proceedings of the 3rd Conference of Mathematical Society of the Republic of Moldova IMCS-50, Chisinau, Aug. 19–23, 2014*, pp. 463–469.